

KRACHT

*A successful future
through experience,
knowledge and technology*



Hydraulic Cylinders CNA

Single and Double-acting

List of Contents

Contents	Page
List of contents	3
Description	4
Types	5
Type code	6
Operating data	7
Pressure/stroke characteristics	8 ... 10
Loading characteristics	11

Dimension sheets

Contents	Page
CNAMounting types 1 and 2	12
CNAMounting type 4	13
CNAMounting type 6	14
CNAMounting type 7	15
CNAMounting type 8	16
CNAMounting type 9	17
Weights – Swivel fittings	18
Spare parts	19
Series CNA-E	20
Proximity switches	21
Accessories	22
Type code CNA-E	23

Description

CNA Cylinders

- Piston Ø 40–125 mm
- Modern seals and guide elements
- Simple replacement of worn parts using robust thread system
- Modular system enables subsequent conversion to alternative applications
- Rod thread, free length, position and size of connections, etc. can be provided to customers' requests.

Available with:

- Adjustable stroke-end damping
- Balancing valves for ganged combinations
- Electronic proximity switches for end of stroke signals
- Electronic stroke measuring system available on application
- Different sealing systems for special applications
- Water cooling for applications in high ambient temperatures
- Other versions available on request

Hydraulic cylinders in the CNA Series are constructed with threaded piston rod ends. The cylinder heads and bases are made from St 52-3.

The cylinders themselves are made from seamless precision steel tube acc. to DIN 2391 and for the ground finished, hard chromed piston rods a high strength steel is used. The pistons and the piston rods incorporate compact seals. The piston rods can be provided with sealing cover sleeves and the cylinders can be supplied complete with FKM seals, to suit operating conditions.

CNA hydraulic cylinders have venting screws at both ends, as standard. If the operating conditions demand it, all sizes of cylinder can also be equipped with adjustable damping at both ends of the stroke.

CNA hydraulic cylinders are available with the following features:

Double-acting with the piston rod on one side (the so-called differential cylinder), or with piston rods on both sides. If the piston rod returns, under the action of external forces, e.g. due to its own weight, or return spring pressure, the differential cylinder can also be used as a single – acting push or pull cylinder, or as a plunger cylinder, i.e. compression cylinder with through-bored piston.

A variation of function is achieved when differential cylinders with the same volumetric stroke are coupled together one behind the other as a so – called synchronised or ganged combination. When installing the cylinder, care should be taken that no radial forces act on the piston rod, otherwise the resulting stresses can quickly lead to failure of the cylinder.

Bolts to quality class 8.8 or 10.9 should be used for the attachment of the cylinder.

Types

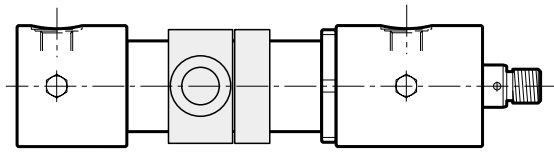

Trunnion mounting on cylinder tube

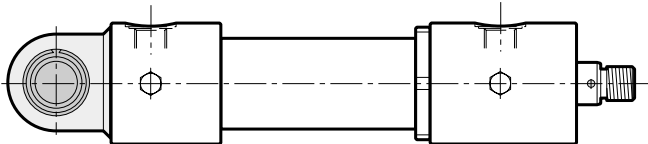

Universal joint or bearing bush on base of cylinder

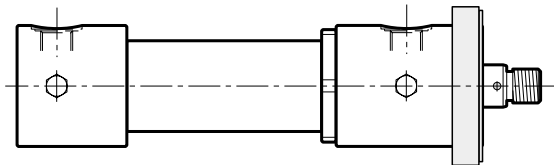

Flange on cylinder head

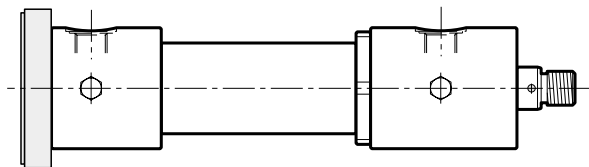

Flange on cylinder base

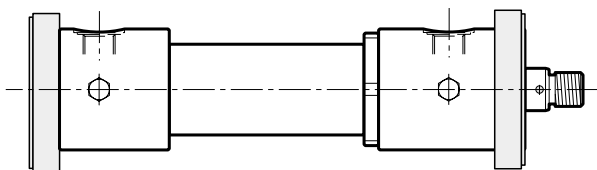

Flange on cylinder head and base

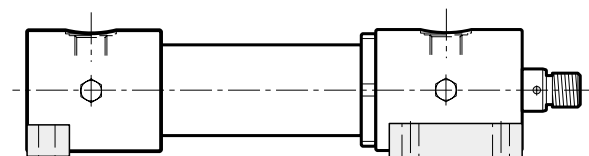

Foot mounting

Type Code

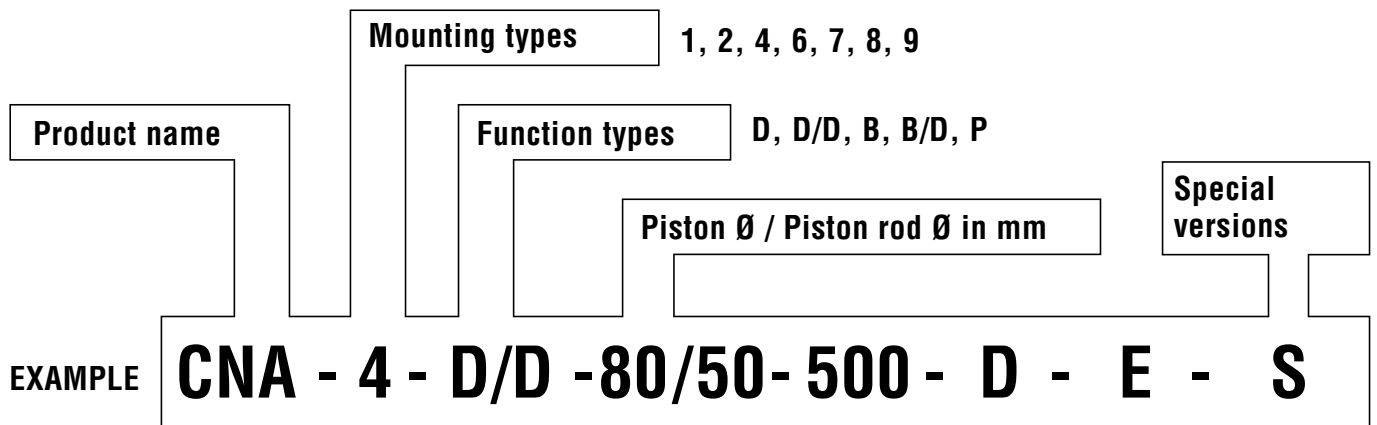

Option:
A = Counterbalance valve for ganged combinations
E = electrical position indicator

Sealing variants **D, VN, VD, G**

Mounting types	
	1 Pivot lug with universal joint
	2 Pivot lug with bush
	4 Trunnion on cylinder tube
	6 Flange mounting on cylinder head
	7 Flange mounting on cylinder base
	8 Flange mounting on cylinder head and on cylinder base
	9 Foot mounted

Function type	
	D Differential cylinder without damping
	D/D Differential cylinder with adjustable damping on both sides
	B Synchronised/ganged cylinder
	B/D Ganged cylinder with adjustable damping on both sides
	P Compression cylinder with through-bored piston (plunger function)

Piston Ø and Piston rod Ø in mm	
normal	extra strength
40/22	40/28
50/30	50/35
63/35	63/45
80/50	80/55
100/60	100/70
125/80	125/90

Sealing variants	
	D Seal/cover sleeve on piston rod
	VN FKM seals with packing ring on the piston rod
	VD FKM seals with sealing sleeve on the piston rod
	G Glyd-Ring seals for Stick-Slip free function

Special versions

e. g.
different thread on piston rod.
Extended free length offset connection operation ...

Operating Data

Cylinders single and double acting

Nominal pressure **200 bar**

General data

Construction piston rod cylinder – threaded version

Variants **see page 5**

Line connections whitworth pipe thread to DIN 2353

Connection size **page 12 ...17**

Equipment dimensions **page 12 ...17**

Weight **page 18**

Installed attitude optional

Ambient temperature with standard seals

$\vartheta_{u \text{ min}}$ = -20 °C

$\vartheta_{u \text{ max}}$ = 80 °C

with FKM seals

$\vartheta_{u \text{ min}}$ = -20 °C

$\vartheta_{u \text{ max}}$ = 180 °C

max. stroke length CNA 40.50 = 3000 mm

CNA 63 - 125 = 4000 mm

Stroke stepping in mm

Hydraulic data

Operating pressure

Piston side p_1 = 0...200 bar

Piston rod side p_3 = 0...200 bar

Temperature

of pressuring medium with standard seals

$\vartheta_{m \text{ min}}$ = -20 °C

$\vartheta_{m \text{ max}}$ = 80 °C

with FKM seals

$\vartheta_{m \text{ min}}$ = -20 °C

$\vartheta_{m \text{ max}}$ = 180 °C viscosity range

v_{min} = 2.8 mm²/s

v_{max} = 380 mm²/s

Permissible speed of travel v = 0...0.5 m/s

(versions for higher operating speeds available on enquiry)

Other hydraulic characteristics are available on enquiry

Actuating pressure fluids mineral oil to DIN 51524/25

flame retardant fluids can be accommodated on enquiry

p-s-characteristic curves Mounting Styles 1 + 2

p = f (s) with standard piston rod

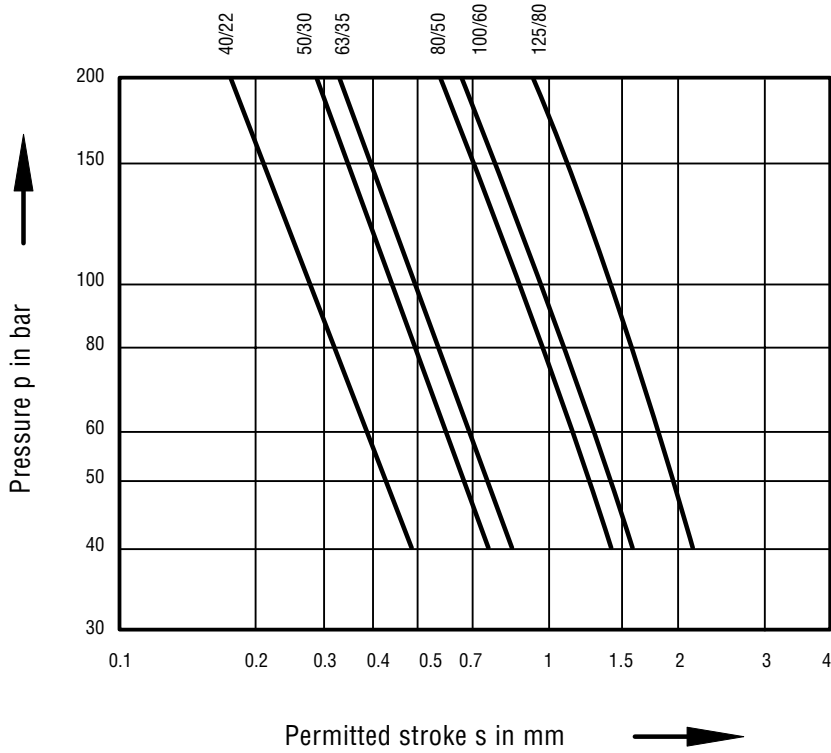
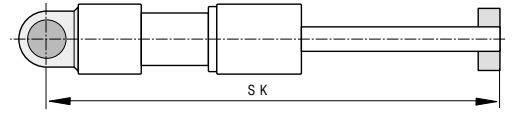

p = f (s) with strengthened piston rod

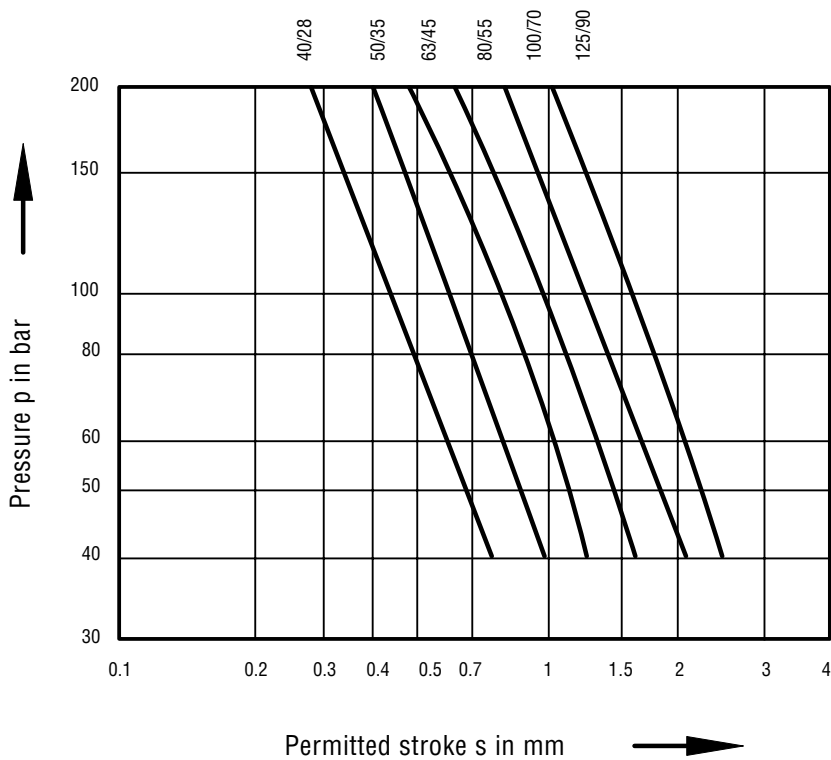

The curves incorporate a safety factor of 3.5 to prevent buckling.

p-s-characteristic curves Mounting Styles 4

p = f (s) with standard piston rod

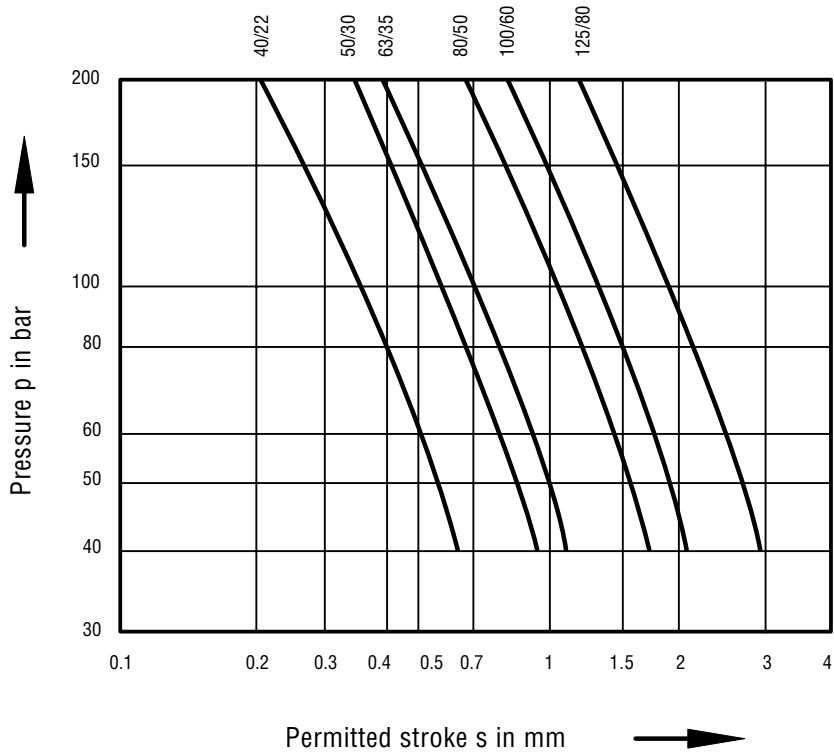
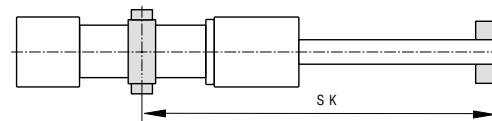

p = f (s) with strengthened piston rod

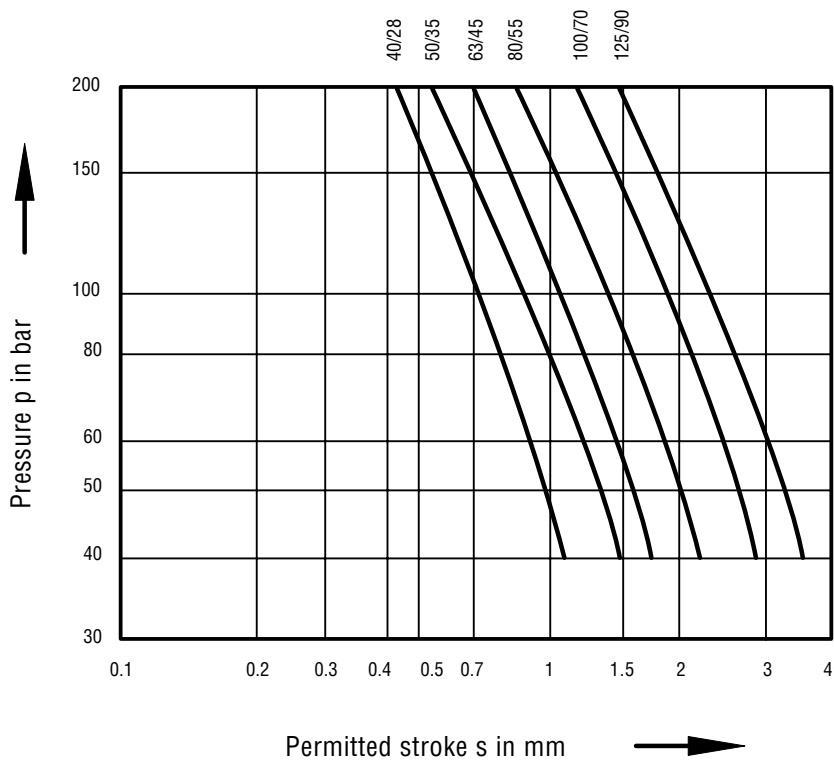

p-s-characteristic curves Mounting Styles 6, 7, 8, 9

p = f (s) with standard piston rod

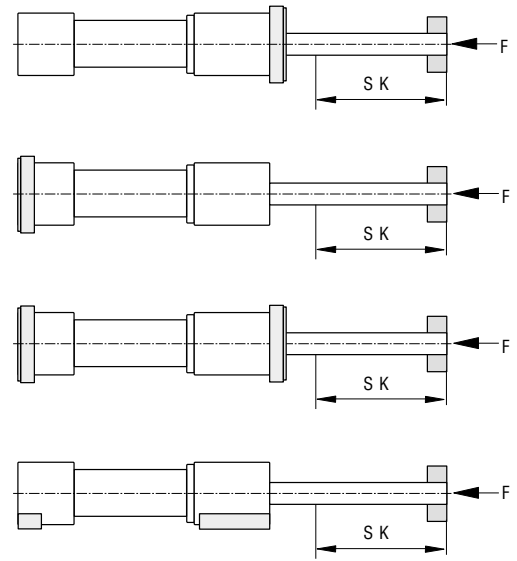
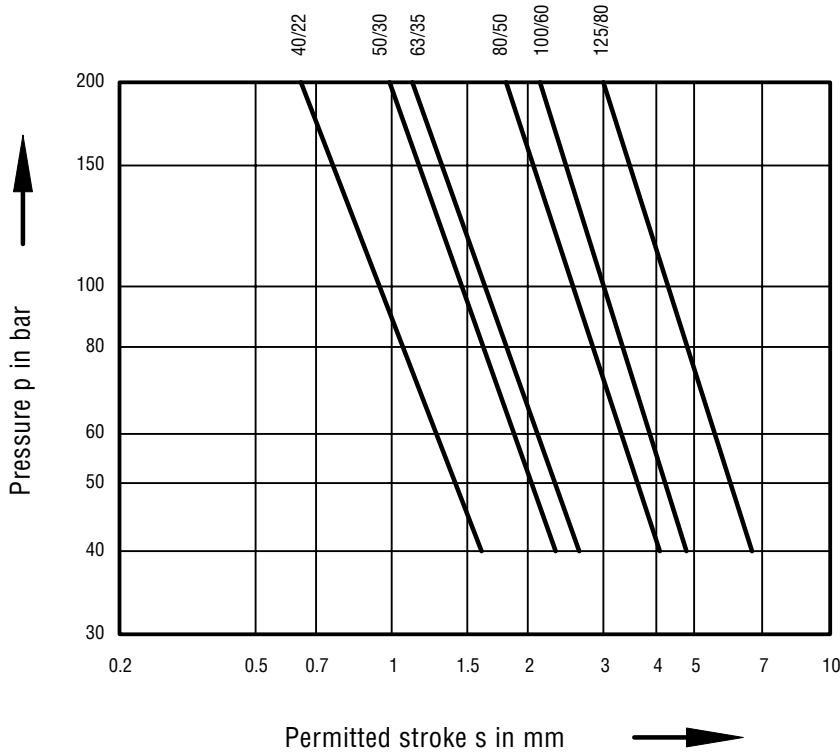

p = f (s) with strengthened piston rod

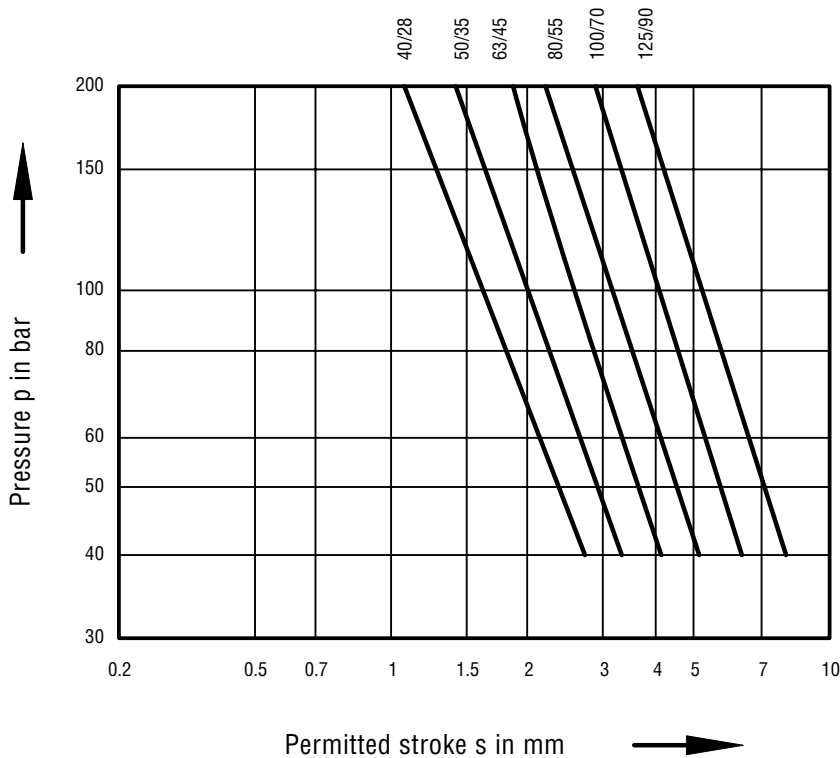

The curves incorporate a safety factor of 3.5 to prevent buckling.

Loading Characteristics

with standard piston rod

— Load F1
(compression)

- - - Load F2
(tension)

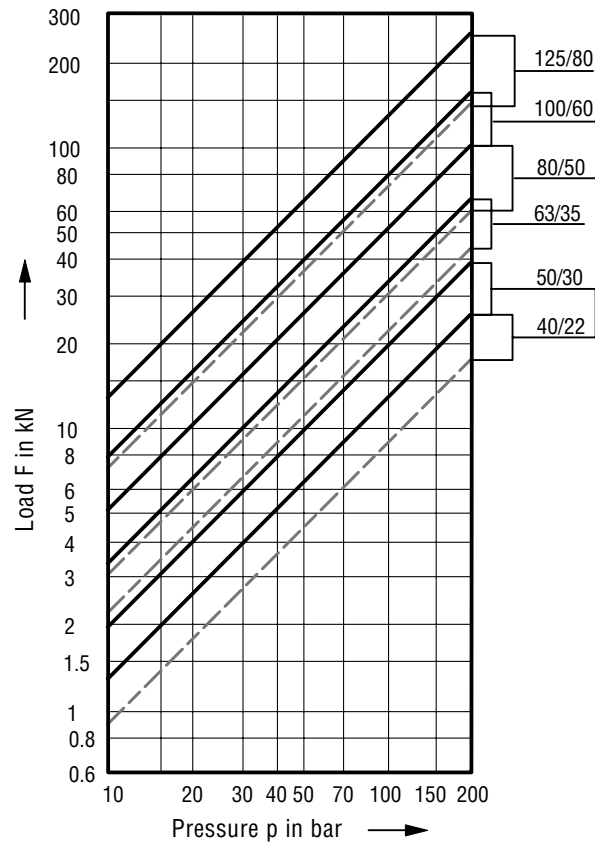

Ganged cylinder operation –
Combination 1

Ganged cylinder operation –
Combination 2

with strengthened piston rod

— Load F1
(compression)

- - - Load F2
(tension)

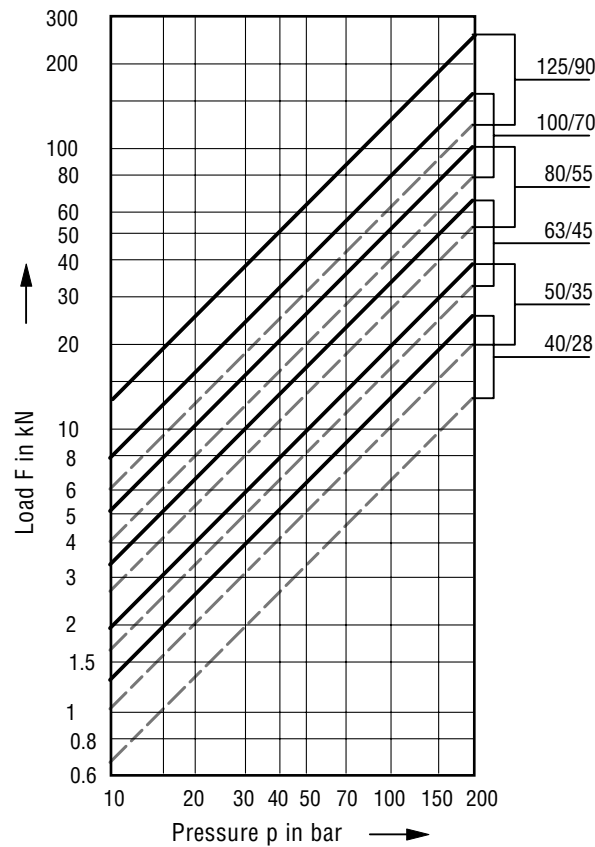

The curves incorporate a safety factor of 3.5 to prevent buckling.

Dimensions 1 + 2

Mounting type 1

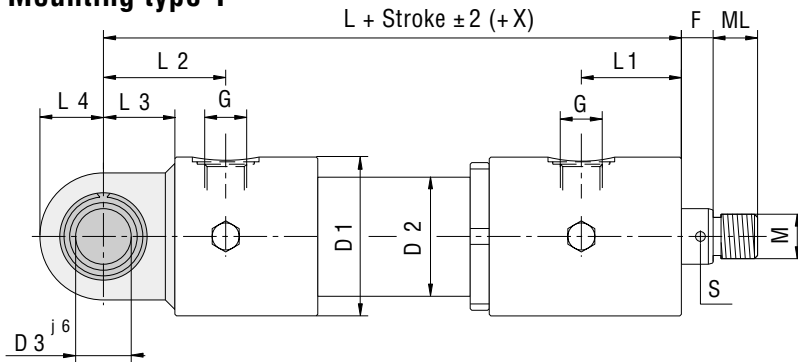

Universal joint on cylinder base

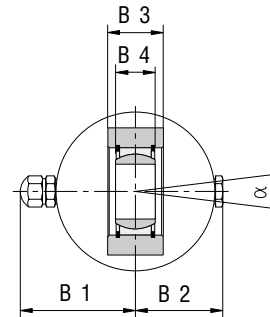

Mounting type 2

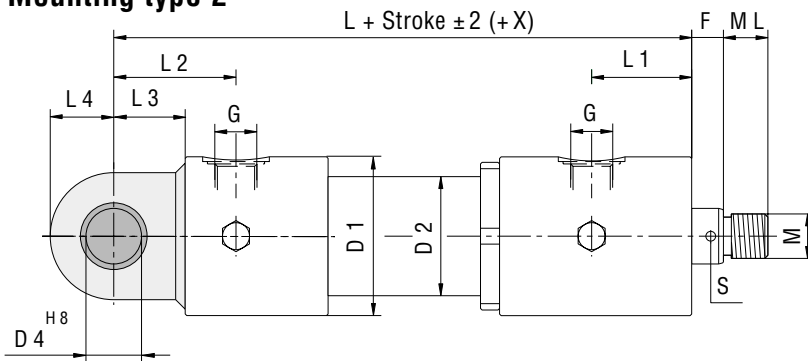

Bearing bush on cylinder base

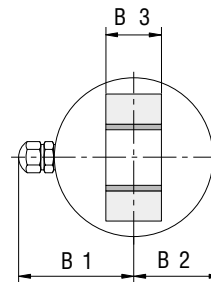

Type	B1	B2	B3	B4	D1	D2	D3	D4	F	G	L	L1	L2	L3	L4	M	MH	ML	S	X	α
CNA- 40	58	40	30	20	70	50	25	25	15	G 1/2	173	43	65	33	30	M16x1.5	40	16	4.5	28	14°
CNA- 50	65	48	30	22	85	60	30	30	15	G 1/2	195	53	68	35	33	M22x1.5	50	22	6	28	12°
CNA- 63	73	55	35	25	100	75	35	35	20	G 3/4	230	63	77	45	40	M28x1.5	45	28	6	20	12°
CNA- 80	83	65	45	28	120	95	40	40	20	G 3/4	260	68	102	55	50	M35x1.5	50	35	8	11	14°
CNA-100	101	78	55	35	145	115	50	50	25	G 1	305	80	106	65	60	M45x1.5	60	45	8	19	12°
CNA-125	114	91	65	44	170	145	60	60	30	G 1 1/2	375	100	125	75	70	M58x1.5	70	58	10	10	12°

Note

- Measure X has to be considered if a cylinder with volumetric balance valves is selected.
- MH (minimum stroke) determines the shortest built-in dimension (L + Stroke ± T).
- Cylinders with strokes less than the given minimum stroke have the same built-in dimensions.

Version with seal variants D + VD

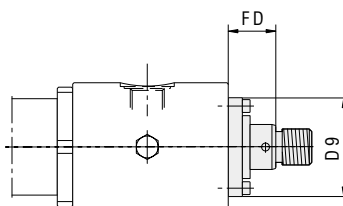

Standard piston rod

	CNA 40/22	50/30	63/35	80/50	100/60	125/80
FD	35	37	37	37	42	60
D9	60	70	75	100	120	145

Strengthened piston rod

	CNA 40/28	50/35	63/45	80/55	100/70	125/90
FD	35	37	37	37	42	60
D9	68	75	85	105	130	150

Dimensions 4

Mounting type 4

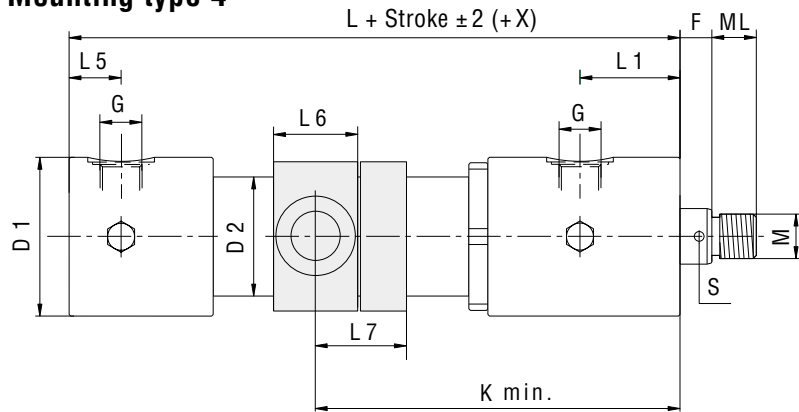

Trunnion mounting on cylinder tube

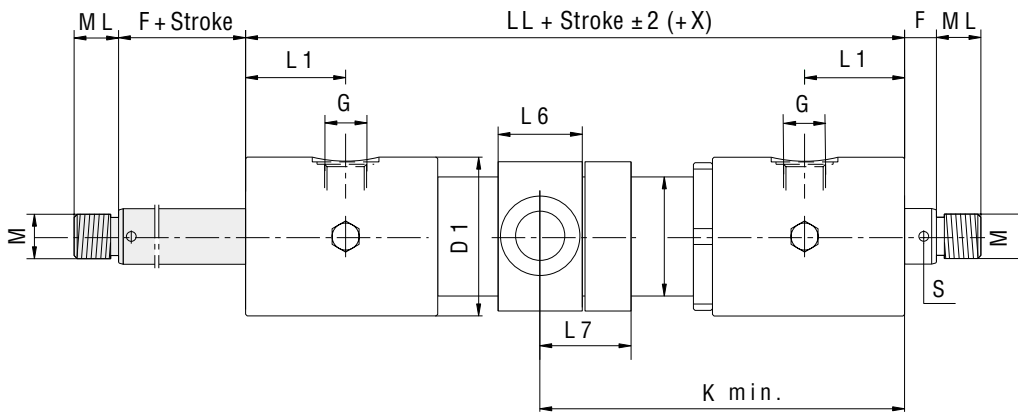
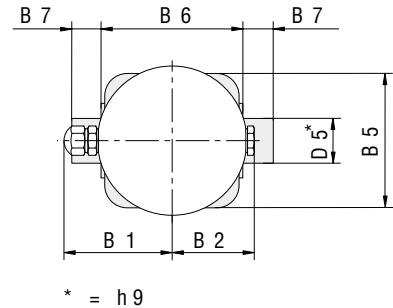

Type	B1	B2	B5	B6	B7	D1	D2	D5	F	G	K _{min}	L	L1	L5	L6	L7	LL	M	MH	ML	S	X
CNA- 40	58	40	70	75	15	70	50	20	15	G 1/2	145	140	43	32	40	43	151	M 16x1.5	105	16	4.5	28
CNA- 50	65	48	80	85	20	85	60	25	15	G 1/2	170	160	53	33	45	49	180	M 22x1.5	125	22	6	28
CNA- 63	73	55	90	95	20	100	75	30	20	G 3/4	195	185	63	32	55	59	216	M 28x1.5	135	28	6	20
CNA- 80	83	65	110	115	25	120	95	40	20	G 3/4	215	205	68	47	65	69	226	M 35x1.5	155	35	8	11
CNA-100	101	78	135	140	35	145	115	50	25	G 1	255	240	80	41	75	80	279	M 45x1.5	175	45	8	19
CNA-125	114	91	170	175	40	170	145	60	30	G 1 1/2	320	300	100	50	90	97	350	M 58x1.5	220	58	10	10

Note

- Measure X has to be considered if a cylinder with volumetric balance valves is selected.
- MH (minimum stroke) determines the shortest built-in dimension (L + Stroke ± T).
- Cylinders with strokes less than the given minimum stroke have the same built-in dimensions.

Version with seal variants D + VD

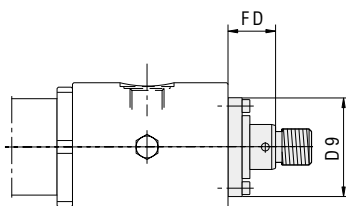

Standard piston rod

CNA	40/22	50/30	63/35	80/50	100/60	125/80
FD	35	37	37	37	42	60
D9	60	70	75	100	120	145

Strengthened piston rod

CNA	40/28	50/35	63/45	80/55	100/70	125/90
FD	35	37	37	37	42	60
D9	68	75	85	105	130	150

Dimensions 6

Mounting type 6

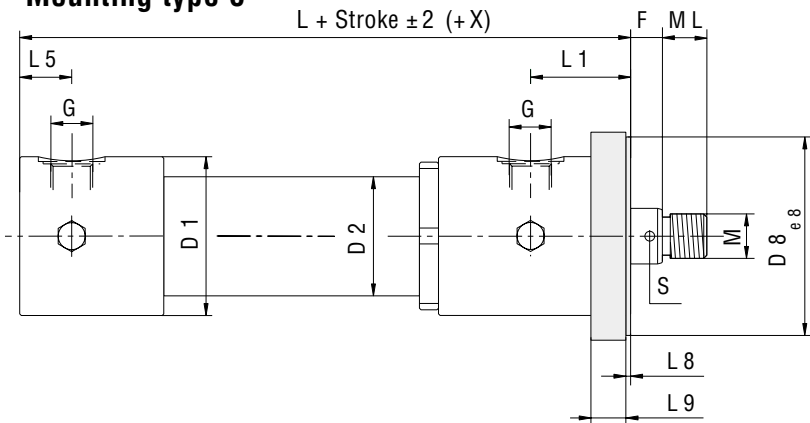

Flange on cylinder head

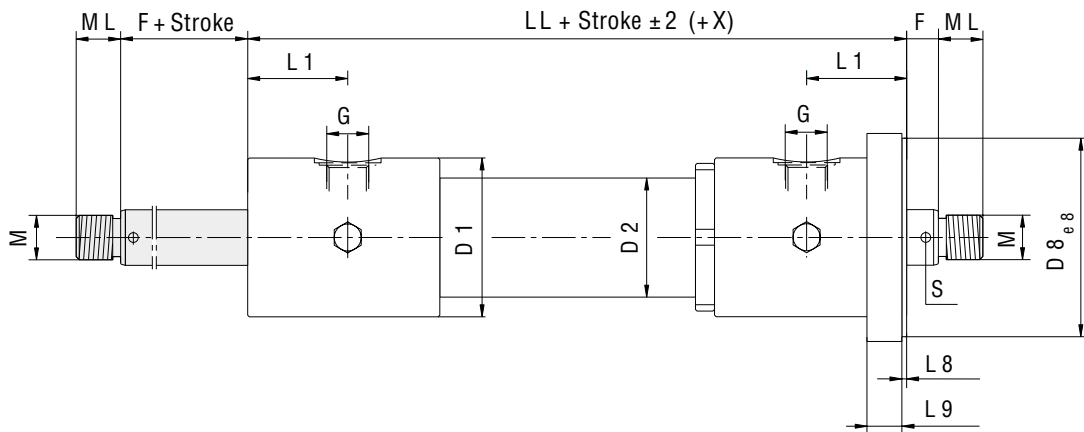
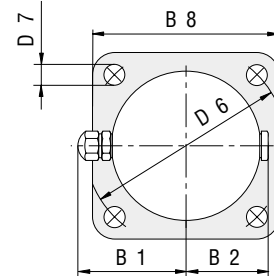

Type	B1	B2	B8	D1	D2	D6	D7	D8	F	G	L	L1	L5	L8	L9	LL	M	MH	ML	S	X
CNA- 40	58	40	97	70	50	105	11	80	15	G 1/2	140	43	32	3	15	151	M 16x1.5	40	16	4.5	28
CNA- 50	65	48	115	85	60	120	14	95	15	G 1/2	160	53	33	3	17	180	M 22x1.5	50	22	6	28
CNA- 63	73	55	125	100	75	135	14	110	20	G 3/4	185	63	32	3	22	216	M 28x1.5	45	28	6	20
CNA- 80	83	65	155	120	95	168	18	135	20	G 3/4	205	68	47	3	27	226	M 35x1.5	50	35	8	11
CNA-100	101	78	185	145	115	205	23	165	25	G 1	240	80	41	5	30	279	M 45x1.5	60	45	8	19
CNA-125	114	91	230	170	145	255	27	210	30	G 1 1/2	300	100	50	5	35	350	M 58x1.5	70	58	10	10

Note

- Measure X has to be considered if a cylinder with volumetric balance valves is selected.
- MH (minimum stroke) determines the shortest built-in dimension (L + Stroke ± T).
- Cylinders with strokes less than the given minimum stroke have the same built-in dimensions.

Version with seal variants D + VD

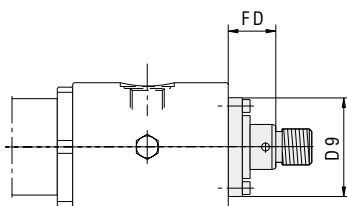

Standard piston rod

CNA	40/22	50/30	63/35	80/50	100/60	125/80
FD	35	37	37	37	42	60
D9	60	70	75	100	120	145

Strengthened piston rod

CNA	40/28	50/35	63/45	80/55	100/70	125/90
FD	35	37	37	37	42	60
D9	68	75	85	105	130	150

Dimensions 7

Mounting type 7

Flange on cylinder base

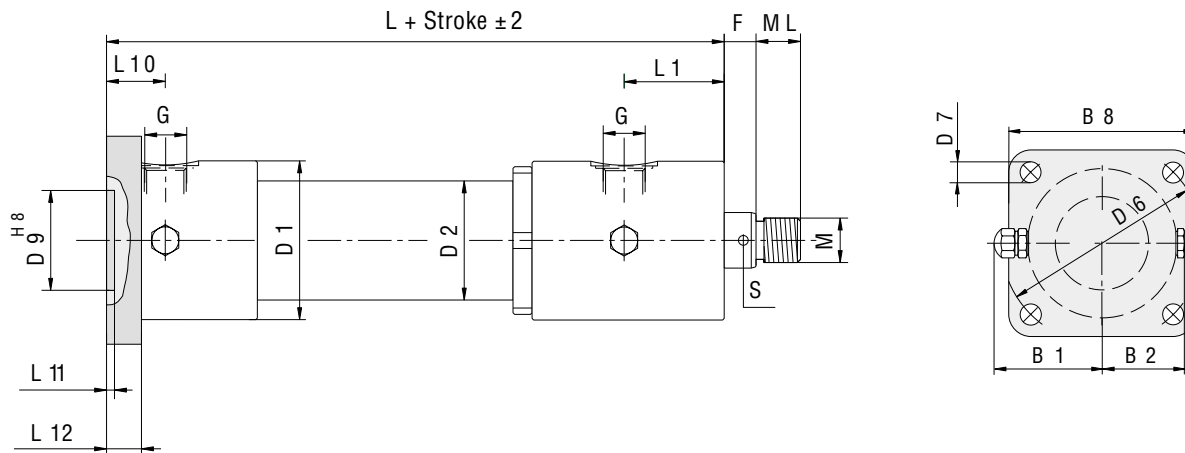

L1	Type B1		B2	B8	D1	D2	D6	D7	D9	F	G	L								
	L10	L11																		
CNA- 40	58	40	97	70	50	105	11	47	15	G 1/2	145	43	37	5	15	M 16x1.5	40	16	4.5	28
CNA- 50	65	48	115	85	60	120	14	55	15	G 1/2	165	53	38	5	17	M 22x1.5	50	22	6	28
CNA- 63	73	55	125	100	75	135	14	63	20	G 3/4	190	63	37	5	22	M 28x1.5	45	28	6	20
CNA- 80	83	65	155	120	95	168	18	80	20	G 3/4	210	68	52	5	27	M 35x1.5	50	35	8	11
CNA-100	101	78	185	145	115	205	23	100	25	G 1	250	80	51	7	30	M 45x1.5	60	45	8	19
CNA-125	114	91	230	170	145	255	27	125	30	G 1 1/2	310	100	60	7	35	M 58x1.5	70	58	10	10

Note

- Measure X has to be considered if a cylinder with volumetric balance valves is selected.
- MH (minimum stroke) determines the shortest built-in dimension (L + Stroke ± T).
- Cylinders with strokes less than the given minimum stroke have the same built-in dimensions.

Version with seal variants D + VD

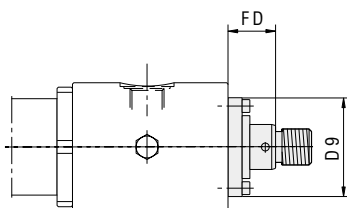

Standard piston rod

	40/22	50/30	63/35	80/50	100/60	125/80
CNA	40/22	50/30	63/35	80/50	100/60	125/80
FD	35	37	37	37	42	60
D9	60	70	75	100	120	145

Strengthened piston rod

	40/28	50/35	63/45	80/55	100/70	125/90
CNA	40/28	50/35	63/45	80/55	100/70	125/90
FD	35	37	37	37	42	60
D9	68	75	85	105	130	150

Dimensions 8

Mounting type 8

Flange on cylinder head and base

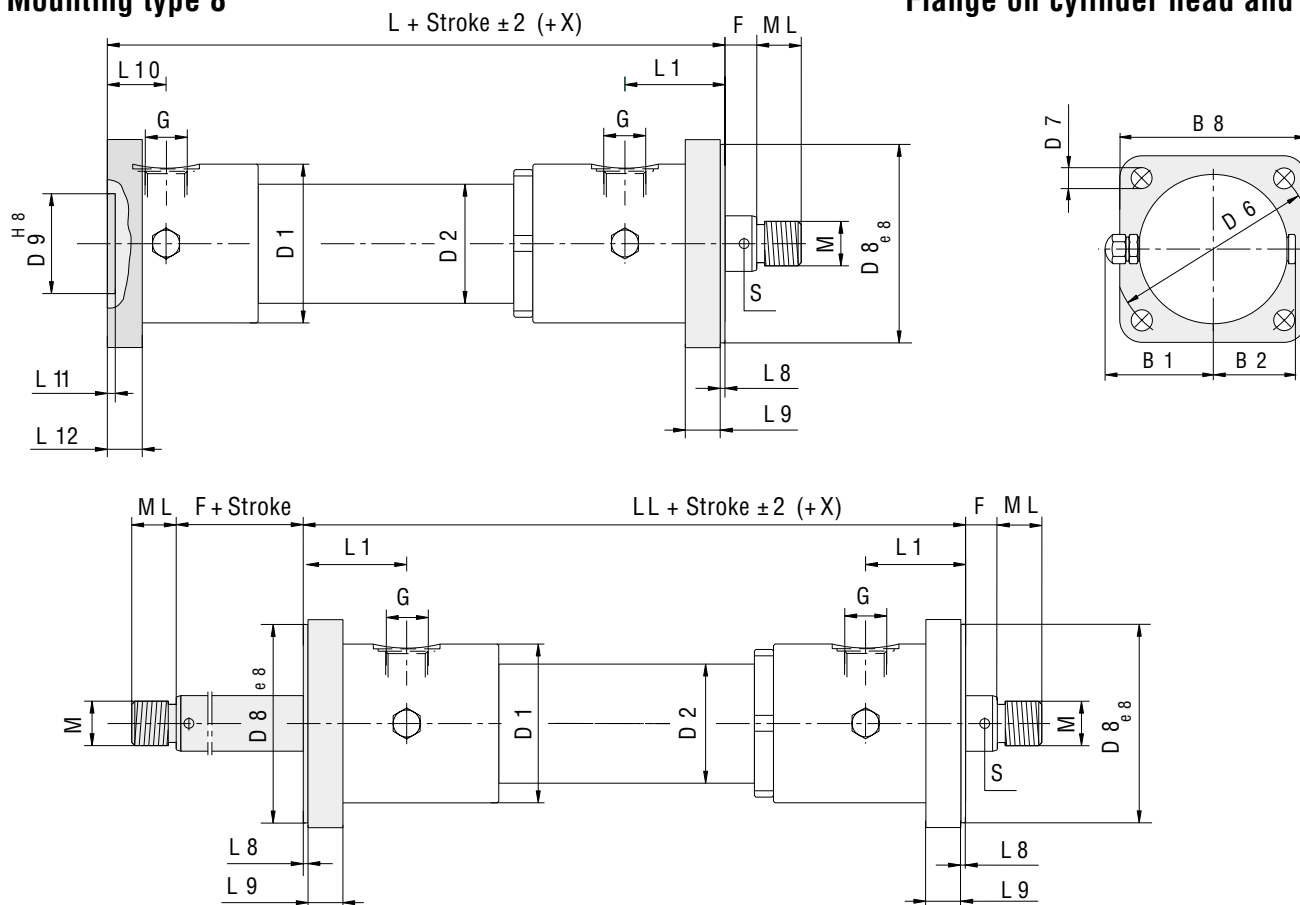

Type	B1	B2	B8	D1	D2	D6	D7	D8	D9	F	G	L	L1	L8	L9	L10	L11	L12	LL	M	MH	ML	S	X
CNA-40	58	40	97	70	50	105	11	80	47	15	G 1/2	145	43	3	15	37	5	15	151	M 16x1.5	40	16	4.5	28
CNA-50	65	48	115	85	60	120	14	95	55	15	G 1/2	165	53	3	17	38	5	17	180	M 22x1.5	50	22	6	28
CNA-63	73	55	125	100	75	135	14	110	63	20	G 3/4	190	63	3	22	37	5	22	216	M 28x1.5	45	28	6	20
CNA-80	83	65	155	120	95	168	18	135	80	20	G 3/4	210	68	3	27	52	5	27	226	M 35x1.5	50	35	8	11
CNA-100	101	78	185	145	115	205	23	165	100	25	G 1	250	80	5	30	51	7	30	279	M 45x1.5	60	45	8	19
CNA-125	114	91	230	170	145	255	27	210	125	30	G 1 1/2	310	100	5	35	60	7	35	350	M 58x1.5	70	58	10	10

Note

- Measure X has to be considered if a cylinder with volumetric balance valves is selected.
- MH (minimum stroke) determines the shortest built-in dimension (L + Stroke ± T).
- Cylinders with strokes less than the given minimum stroke have the same built-in dimensions.

Version with seal variants D + VD

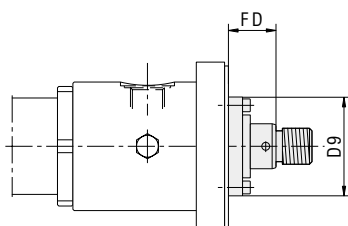

Standard piston and piston rod

CNA	40/22	50/30	63/35	80/50	100/60	125/80
FD	35	37	37	37	42	60
D9	60	70	75	100	120	145

Strengthened piston and piston rod

CNA	40/28	50/35	63/45	80/55	100/70	125/90
FD	35	37	37	37	42	60
D9	68	75	85	105	130	150

Dimensions 9

Mounting type 9

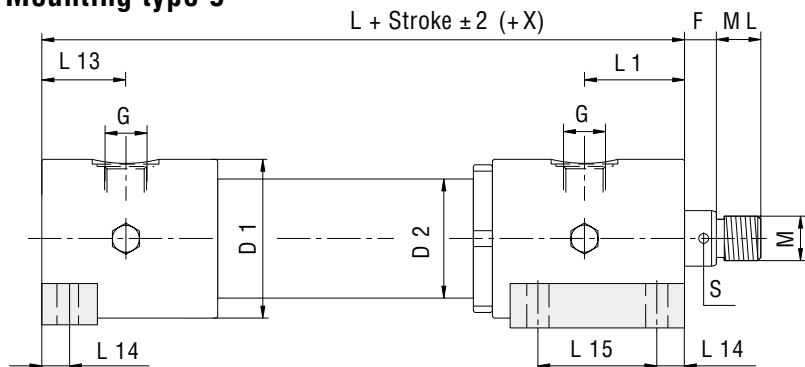

Foot mounting

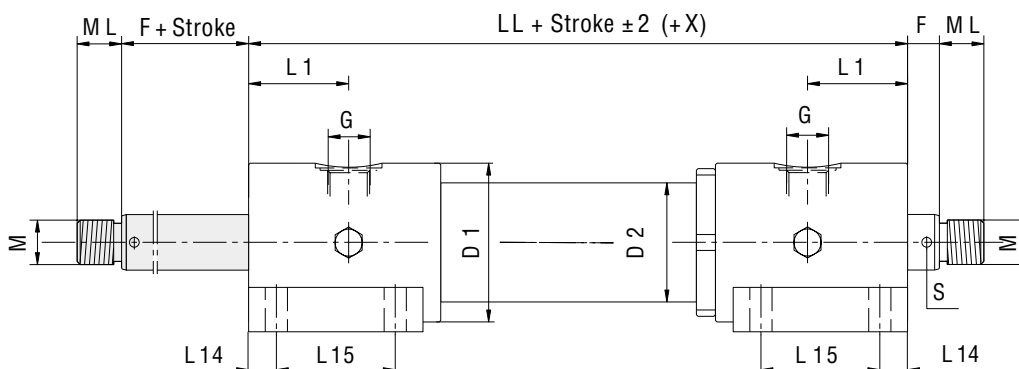
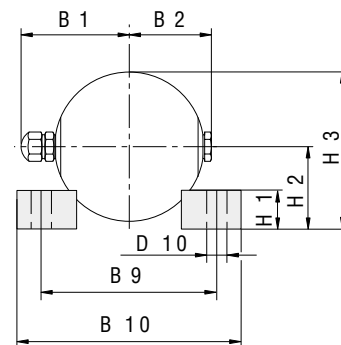

Type	B1	B2	B9	B10	D1	D2	D10	F	G	H1	H2	H3	L	L1	L13	L14	L15	LL	M	MH	ML	S	X
CNA- 40	58	40	85	110	70	50	9	15	G 1/2	18	38	73	148	43	40	12.5	57	151	M 16x1.5	40	16	4.5	28
CNA- 50	65	48	105	135	85	60	11	15	G 1/2	22	45	87.5	167	53	40	15	67	180	M 22x1.5	50	22	6	28
CNA- 63	73	55	120	150	100	75	14	20	G 3/4	28	56	106	206	63	53	17.5	75	216	M 28x1.5	45	28	6	20
CNA- 80	83	65	145	180	120	95	18	20	G 3/4	32	62	122	208	68	50	17.5	85	226	M 35x1.5	50	35	8	11
CNA-100	101	78	170	220	145	115	22	25	G 1	40	80	152.5	264	80	65	25	100	279	M 45x1.5	60	45	8	19
CNA-125	114	91	220	270	170	145	27	30	G 1 1/2	45	100	185	300	100	50	30	130	350	M 58x1.5	70	58	10	10

Note

- Measure X has to be considered if a cylinder with volumetric balance valves is selected.
- MH (minimum stroke) determines the shortest built-in dimension (L + Stroke ± T).
- Cylinders with strokes less than the given minimum stroke have the same built-in dimensions.

Version with seal variants D + VD

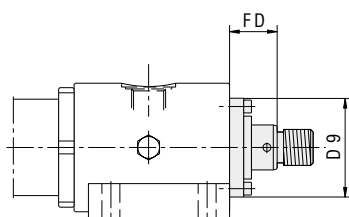

Standard piston rod

CNA	40/22	50/30	63/35	80/50	100/60	125/80
FD	35	37	37	37	42	60
D9	60	70	75	100	120	145

Strengthened piston rod

CNA	40/28	50/35	63/45	80/55	100/70	125/90
FD	35	37	37	37	42	60
D9	68	75	85	105	130	150

Weights

Weights of versions D + D/D

Type	Basic weight in kg for mounting type ...			Weight per mm of stroke in kg for rod diameter ...			
	1 + 2	4 + 8	6 + 7 + 9	Ø	Weight	Ø	Weight
CNA- 40	5.6	6.5	5.8	22	0.009	28	0.011
CNA- 50	8.8	10.2	9.5	30	0.013	35	0.015
CNA- 63	15.0	16.2	15.5	35	0.016	45	0.023
CNA- 80	23.2	25.6	24.2	50	0.032	55	0.035
CNA-100	41.5	46.5	47.5	60	0.042	70	0.052
CNA-125	61.5	69.0	66.5	80	0.073	90	0.083

Weights of versions B + B/D

Type	Basic weight in kg for mounting type ...			Weight per mm of stroke in kg for rod diameter ...			
	4	6	8 + 9	Ø	Weight	Ø	Weight
CNA- 40	7.2	6.6	7.6	22	0.012	28	0.013
CNA- 50	12.1	11.3	12.8	30	0.018	35	0.019
CNA- 63	19.5	18.5	20.5	35	0.025	45	0.029
CNA- 80	33.5	32.0	33.0	50	0.047	55	0.050
CNA-100	56.3	53.3	59.5	60	0.064	70	0.072
CNA-125	96.0	92.0	98.0	80	0.110	90	0.122

Swivel fittings

Note on assembly:

The swivel fittings should not butt up against the end of the piston rod, since there is then a risk of wear on the piston rod thread due to the clamping action of the cheese head screws.

Note on ordering:

The swivel fittings should be ordered separately

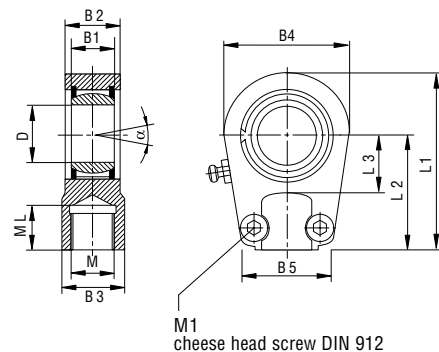

Swivel fittings	B1	B2	B3	B4	B5	D	L1	L2	L3	M	M1	ML	α	Weight in kg
GLK- 40 B	20	23	25	56	41	25	78	50	25	M 16 x 1.5	M 8	17	14°	0.5
GLK- 50 B	22	28	32	64	46	30	92	60	30	M 22 x 1.5	M 8	23	12°	0.75
GLK- 63 B	25	30	40	78	58	35	109	70	38	M 28 x 1.5	M 10	29	12°	1.2
GLK- 80 B	28	35	49	94	66	40	132	85	45	M 35 x 1.5	M 10	36	14°	2.0
GLK-100 B	35	40	61	116	88	50	163	105	55	M 45 x 1.5	M 12	46	12°	3.8
GLK-125 B	44	50	75	130	90	60	200	130	65	M 58 x 1.5	M 12	59	12°	5.4

Spare Parts

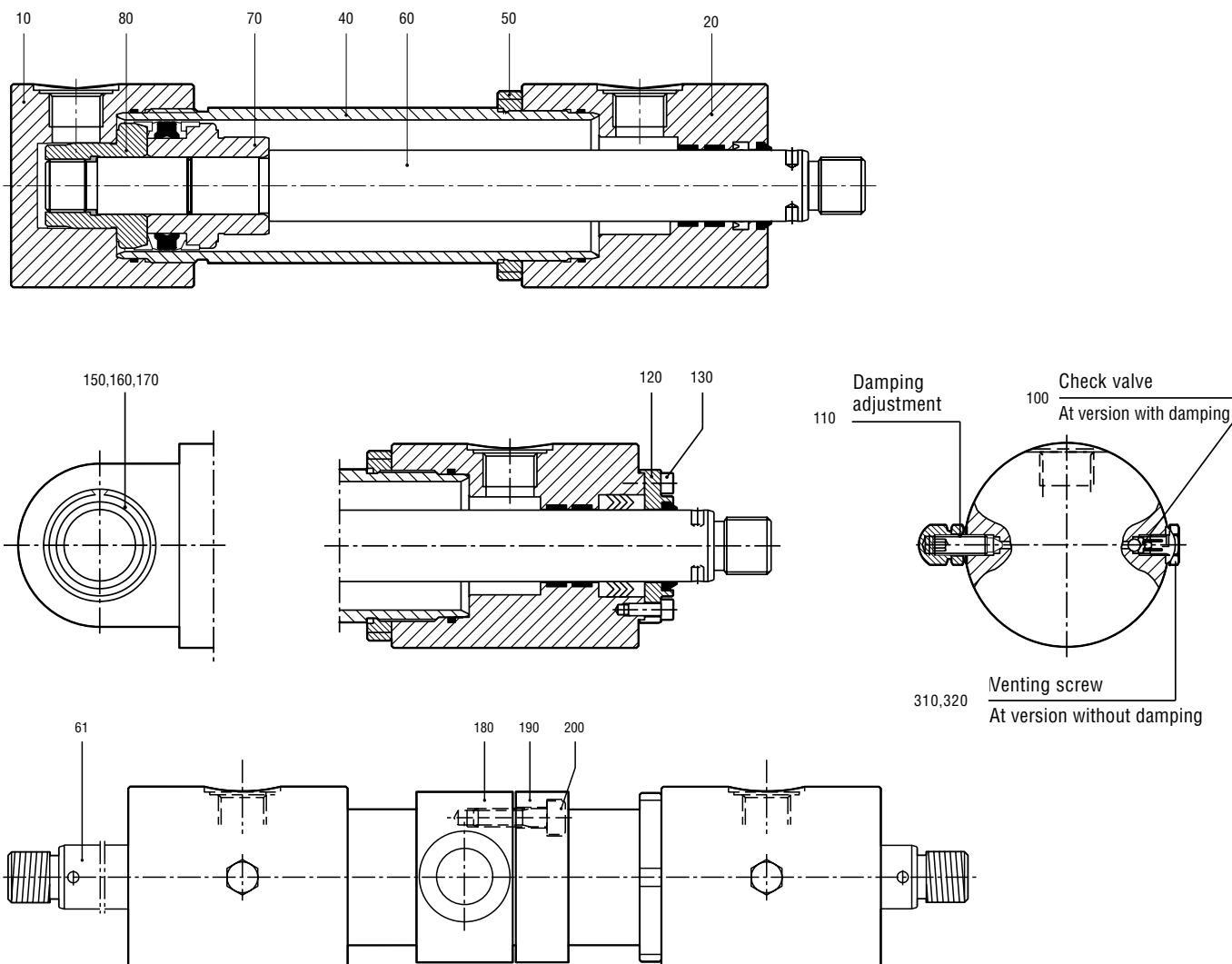

Item	Description	Item	Description	Item	Description	Item	Description
10	Cylinder base	70	Piston	150	Universal bearing	310	Venting screw
20	Cylinder head	80	Piston half	160	Retaining ring	320	Sealing ring
40	Cylinder tube	100	Check valve	170	Bush	450	Seal insert
50	Lock ring	110	Throttle valve	180	Harness ring		
60	Piston rod	120	Cover *	190	Locking ring		
61	Piston rod "B"	130	Cheese head screw *	200	Cheese head screw		

* only at version "D" and "VD"
(sealing sleeve)

Ordering example:	Item	Quantity	Description	Cylinder code (see type plate)
	60	2	Piston rod	CNA-2-D/D-100/60-400

Type CNA-E Series with electronic proximity switches

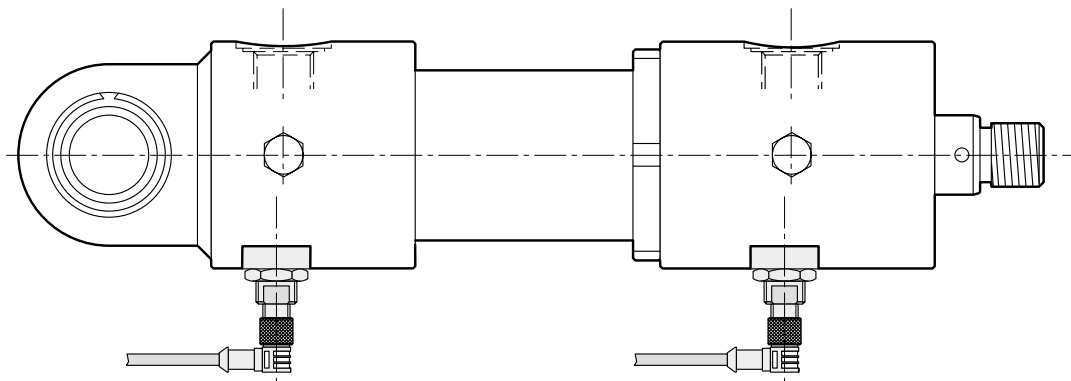

Description:

Electronic proximity switches are used in the place of mechanical limit switches when reliable and precise end-of-stroke signals are required. The signals are suitable for activation from all standard PLC controls and also from relays.

Features:

- Reliable end position signal
- Resistant to external environment effects
- Suitable for connection to PC's
- Integrated short-circuit protection
- Pressure-tight to 500 bar static, 350 bar dynamic
- Zero-contact and non-contacting switching, hence no wear in operating system

Built-in proximity switch

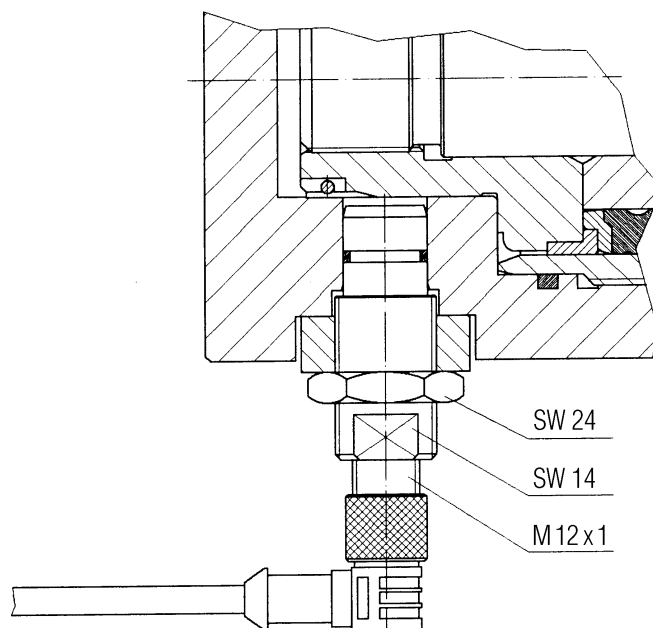

Proximity switches BID 2 – G180 – AP6 – ...

Construction and principle of operation

The basis for the inductive switching principle is an HF-oscillator that can be influenced from an external source using an LC resonant circuit.

The oscillator coil, built into a ferrite core, generates a high frequency alternating effect over the active surface.

If metal is brought into the alternating field, an interaction occurs at the oscillator, that is converted into a switching command. When complete damping of the active surface occurs, the vibration of the oscillator is chopped completely.

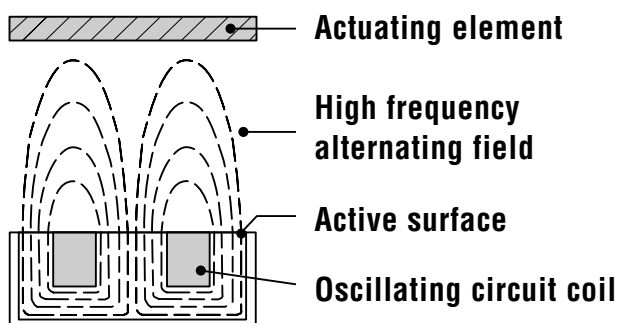

Proximity switch not activated (oscillator undamped)

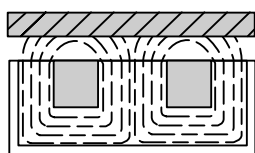

Proximity switch activated (oscillator damped)

Connection diagram:

Connector as seen from the front.

The following international colour identification applies to proximity switches with plug connectors:

- bk = black = **A**
- bn = brown = **+**
- bu = blue = **-**

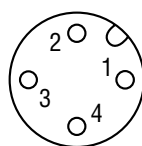
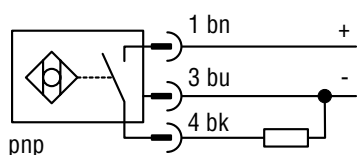

Technical data

Housing style	threaded barrel, M18 x 1
Dimensions	58 mm
Housing material	metal, A2 1.4305 (AISI 303)
Active face material	plastic, PA12-GF30
Rated pressure on frontcap	≤ 100 bar
Max. fixing torque of coupling nut	25 Nm
Connection	connector, M12 x 1
Vibration resistance	55 Hz (1 mm)
Shock resistance	30 x g (11 ms)
Rated operating distance S_n	2 mm
Mounting mode	flush
Pressure static	≤ 500 bar
Pressure dynamic	≤ 350 bar
Permitted contact medium	electrically non-conductive
Temperature drift	≤ ± 10 %
Hysteresis (switching distance)	3 ... 15 %
Repeat accuracy	≤ 2 %
Operating temperature	-10 ... +70 °C

Electrical data

Rated operational voltage U_B	10 ... 30 VDC
Max. ripple	≤ 10 % U_{pp}
Rated operational current (DC) I_e	≤ 200 mA
No-load current I_o	≤ 15 mA
Max. OFF-state current	≤ 0.1 mA
Rated insulation voltage	≤ 0.5 kV
Short-circuit protection	yes, cyclic
Max. voltage drop at I_e	≤ 1.8 V
Wire breakage/reverse polarity protection	yes, complete
Output function	3-wire, normally open, PNP
Max. switching frequency	≤ 2 kHz
Degree of protection	IP67

The proximity switch switches by means of a damping sleeve and pin at the end position in the cylinder.

The switching point lies between 7 and 8 mm before the end position, which is determined mechanically by the cylinder.

The accuracy of repeatability is 0.5 mm.

Accessories

WWAK 3P2 - . / S90

. = Cable length in m

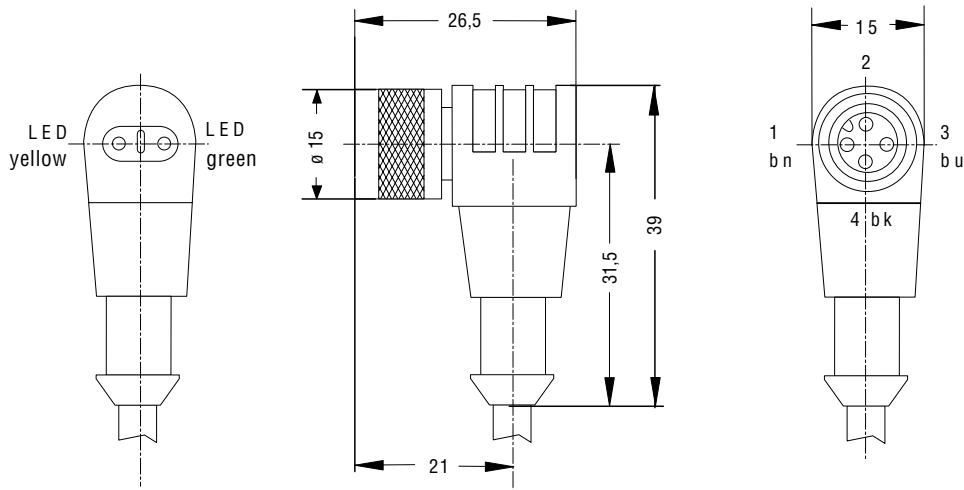

Electrical data

Connector	coupling, M12 x 1, angled	Rated voltage	10 ... 30 V AC/DC
Number of poles	3 poles	Isolation resistance	$\geq 10^9 \Omega$
Contacts	metal, CuZn, gold-plated	Ampacity	4 A
Contact carrier	plastic, TPU, black	Volume resistance	$\leq 5 \text{ m}\Omega$
Body	plastic, TPU, transparent	Ambient temperature connector	-30 ... +90 °C
Switching function	pnp	Ambient temperature cable	-40 ... +80 °C
Coupling nut	metal, CuZn, nickel-plated		at temperatures under -25 °C the cables must not be moved
Sealing	plastic, FKM		
Protection class	IP67, only in screwed status		
Supply voltage	LED green		
Switching status display	LED yellow		
Mechanical life cycle	max. 100 contact durability		
Degree of pollution	3/2		
Cable	S90, LifYY11Y, 5.2 mm Ø		
Cable length	2 m		
Cable jacket	PUR/PVC, grey		
Material wire isolation	PVC		
Colour wire isolation	BN, BU, BK		
Cross section of wire	3 x 0.34 mm ²		
Wire build-up	43 x 0.1 mm ²		
Bending radius (disposed condition)	at least 10 x cable diameter		

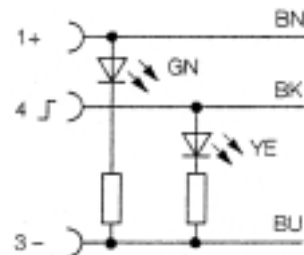

Type Code with electrical end position indication

EXAMPLE

CNA - 4 - D/D - 80/50 - 500 - D - E - S

Order example: CNA -1-D/D-63/35-200-D-EB + WWAK3P2-./S90

Electrical end position indication

E	prox. switch on head and base
EK	prox. switch on head
EB	prox. switch on base
ES	fastener element on head and base
EKS	fastener element on head
EBS	fastener element on base

Dimensions

proximity switch relay

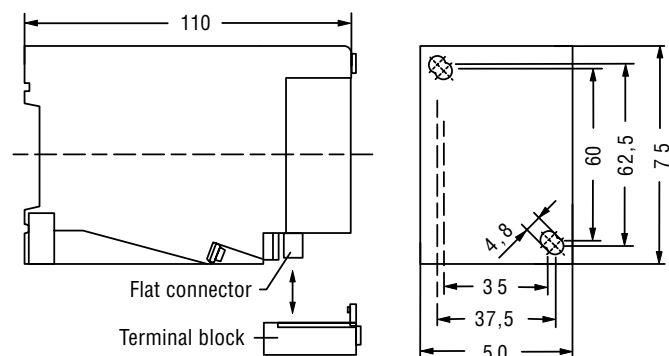

Circuit example

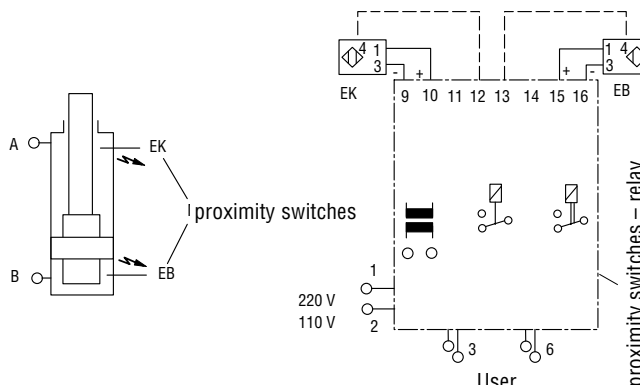

Proximity switch – Relay

Current supply and interface unit for max. 2 DC proximity switch.

Output: 2 relays, each 1 U.
LED indicators for operating status of the output relay.
Output relay logic operations through series or parallel circuitry are possible.

Type of construction

Plastic housing with top-mounted connection terminals. Item replacement without wiring disconnection through use of detachable terminal blocks.
Terminal blocks prevented from misalignment.
Finger contact safety to DIN 57106.

Elektrical data

Operating voltage	220 VAC / 110 VAC
Power consumption	ca. 6 VA
Control circuit	terminals 9 – 6
Ripple	≤ 10%
Perm. loading	max. 120 mA
Contact circuit	terminals 3 – 8
Contact material	AgCd0
Perm. loading	≤ 250 VAC, ≤ 4 A, cos φ ≥ 0,7
Switching frequency	30 Hz
Response time	ca. 15 ms
Drop-out time	ca. 15 ms
Climatic classification	HUG (–25 °C to +60 °C)

Fixing

Mounting by snap-on fixing on standard 35 mm profile rail (to DIN 46277) or by 2 M4 screws to DIN 43660.

Protection class

Housing	IP 30
with terminal blocks	IP 20

Isolation

to VDE 0110, group C
max. ambient temperature up to +65 °C

Overview of our complete program

Transfer pumps

Transfer pumps for lubricating oil supply equipment, low pressure filling and feed systems, dosing and mixing systems.

Flow measurement

Gear and turbine flow meters and electronics for volume and flow metering technology in hydraulics, processing and laquering technology.

Mobile hydraulics

Single and multistage high pressure gear pumps, hydraulic motors and valves for construction machinery, vehicle-mounted machines.

Industrial hydraulics

Directional control and proportional valves to Cetop. Hydraulic cylinders, pressure, quantity and stop valves for pipe and slab construction, hydraulic accessories for industrial hydraulics (mobile and stationary use).

With our decades of experience, we are at your side, world-wide, for the professional mastery of specific applications and complete solutions in hydraulics and process technology.



CNA/e/02.06